



Duckworth & Kent
titanium surgical instrument manufacturer

at the leading edge

Femtosecond Laser Instruments Including LASIK & LASEK



Exceptional Engineering
Ergonomic Design

Find us on



Specula

9-583

Williams Adjustable LASIK Speculum

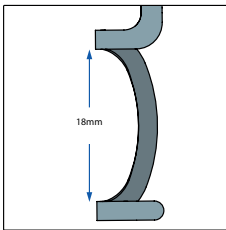

Designed to achieve maximum comfortable exposure of eye for suction ring placement to allow microkeratome to be easily positioned on the pivot post without obstruction during LASIK surgery. Lengthened speculum blades accommodate microkeratome. Simplicity and elegance of design allows speculum to be used in other types of ocular surgery.

- 18mm open blades
- Angled to rest temporarily
- Adjustable with thumb screw

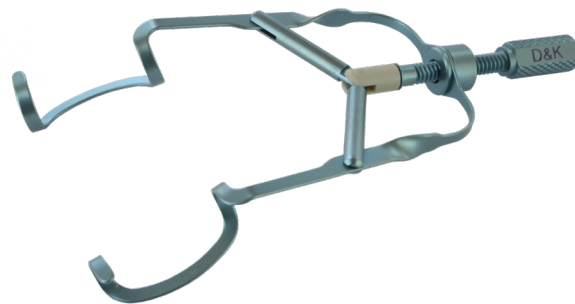

9-588-2

Horn Adjustable Femtosecond Laser Speculum

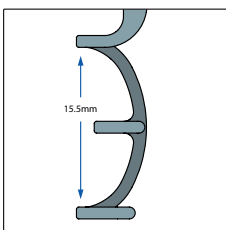

The Horn Adjustable Femtosecond Laser Speculum has been designed with curved blades to allow clearance for docking devices, allowing exposure centrally without stretching the lids laterally, providing optimal exposure as well as patient comfort.

- 15.5mm open blades
- Curved to rest temporarily
- Adjustable with thumb screw
- Suitable for femtosecond laser
- Can be used for cataract surgery and LASIK



9-589

Buratto Adjustable Speculum

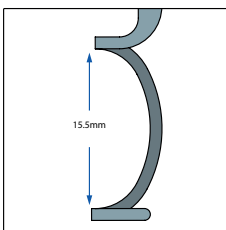

Lightweight, compact and strong. Maximum exposure allows application of suction ring and microkeratome run.

- 15.5mm open blades
- Angled to rest nasally
- Adjustable with thumb screw

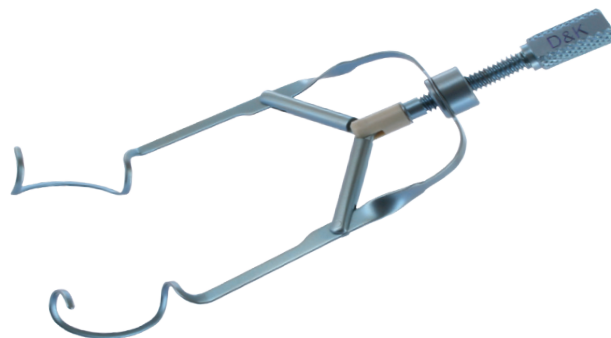

9-588

Buratto Adjustable Speculum

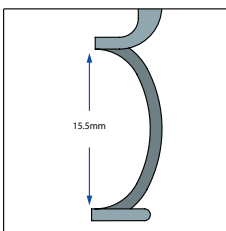

Lightweight, compact and strong. Maximum exposure allows application of suction ring and microkeratome run.

- 15.5mm open blades
- Angled to rest temporarily
- Adjustable with thumb screw

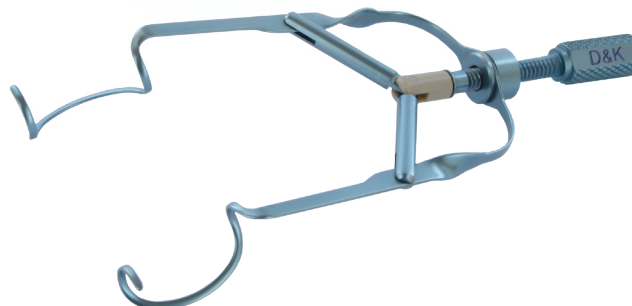

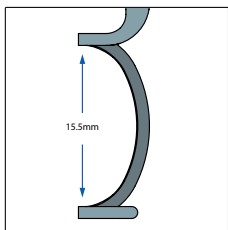

Maximum blade exposure allows application of suction ring when using the LenSx® Laser. LenSx® is registered to Alcon LenSx Inc.

- 15.5mm open blades
- Curved to rest temporally
- Adjustable with thumb screw
- Suitable for femtosecond laser

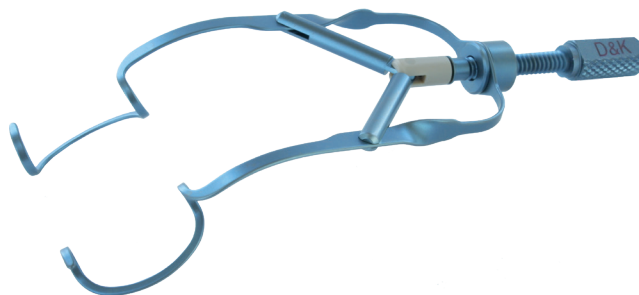

Example 1

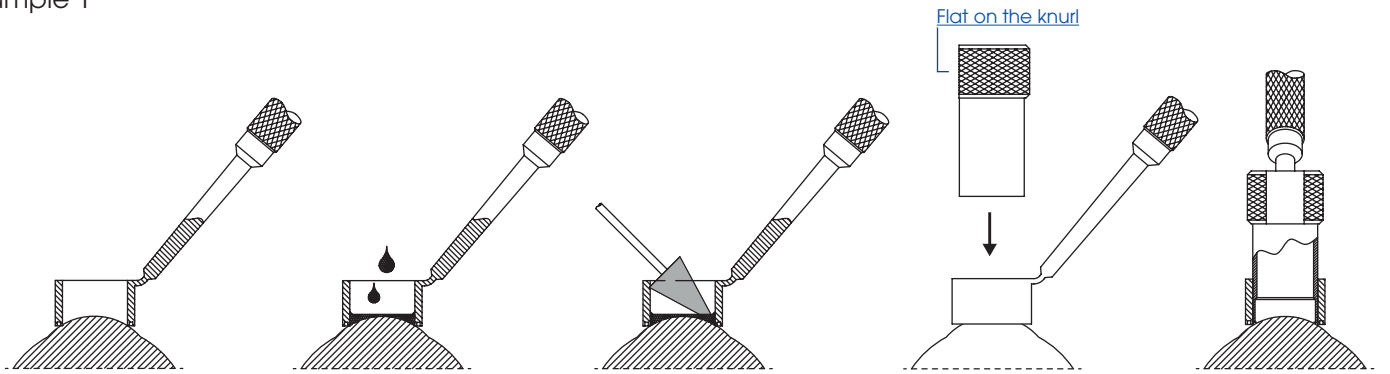

1. Centre alcohol chamber onto eye

2. Apply alcohol mixture into the chamber, covering the epithelium, and leave for the required time to soften the epithelium.

3. Soak up the excess alcohol.

Flat on the knurl

4. Place the trephine into the alcohol chamber. The flat on the knurl of the trephine signifies the location of the hinge of the epithelium flap. Apply enough downward pressure with a slight twist in order to cut the tissue of the epithelium.

Example 2

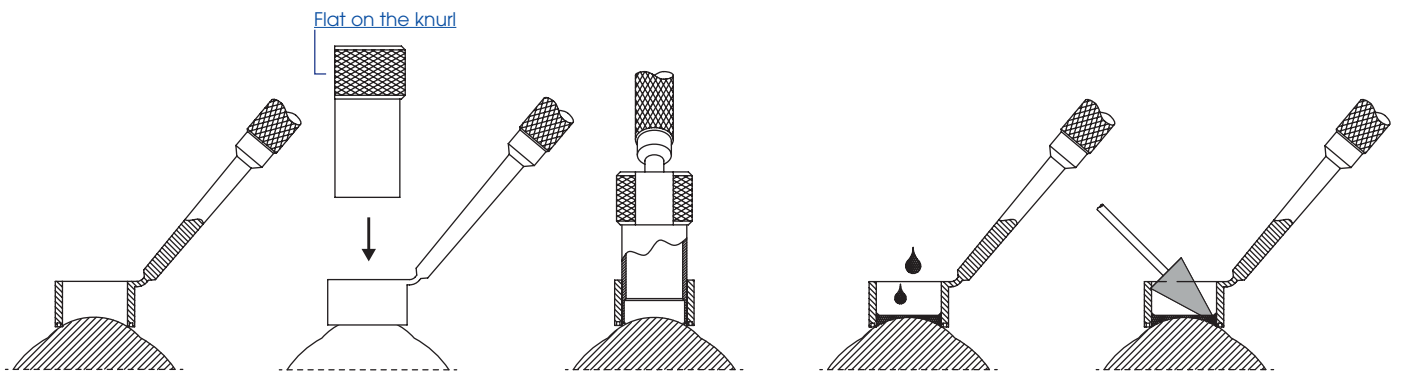

1. Centre alcohol chamber onto eye

Flat on the knurl

2. Place the trephine into the alcohol chamber. The flat on the knurl of the trephine signifies the location of the hinge of the epithelium flap. Apply enough downward pressure with a slight twist in order to cut the tissue of the epithelium.

3. Apply alcohol mixture into the chamber, covering the epithelium, and leave for the required time to soften the epithelium.

4. Soak up the excess alcohol.

Continuation after example 1 or 2

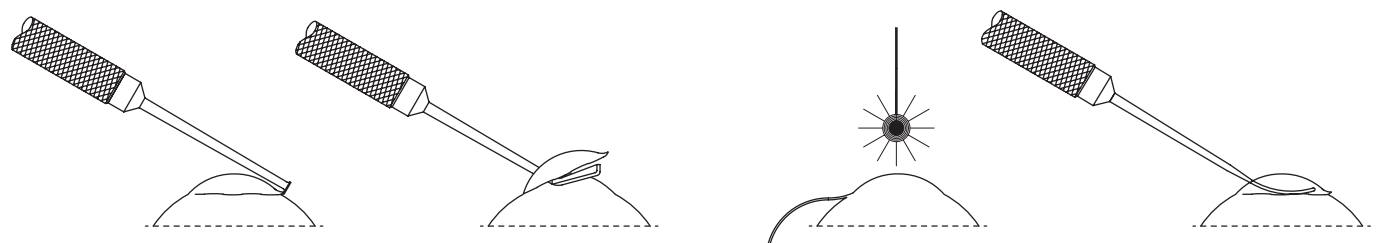

5. Remove the alcohol chamber, then lift the edges around the incision of the epithelial flap.

6. Once the edges are raised, use the 6-866 (shown) to separate and lift the epithelium.

7. Apply Laser.

8. Following the application of the laser, use the spatula (6-103-1) to replace and smooth the epithelial flap.

LASEK Trephines

Incision Diameter	Epithelial Trephine Product Number	Trephine Guide and Alcohol Chamber Product Number	Bates Trephine Guide and Alcohol Chamber with Fixation Product Number
8mm	6-924	6-944	6-944-1
8.5mm	6-925	6-945	6-945-1
9mm	6-926	6-946	
9.5mm		6-947	
10mm	6-928		
10.5mm	6-929		
11mm	6-930		



Order Separately

6-924

DK Epithelial Trephine for LASEK (Ø8.0mm incision)

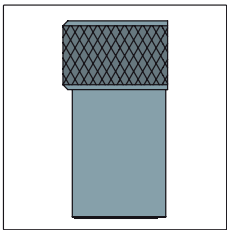

- 8mm incision
- Used with 6-944, DK 8mm trephine guide - alcohol

See above table for various incision diameters.



6-944

DK 8mm Trephine Guide - Alcohol Chamber

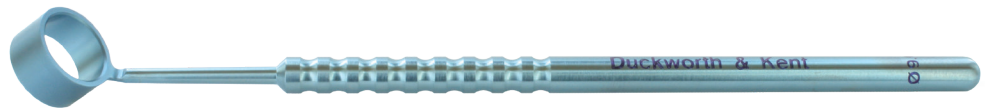
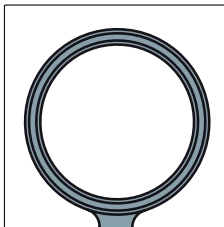
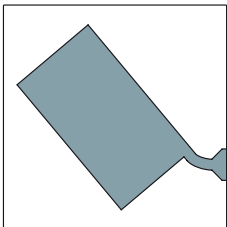

- Alcohol chamber, height 6mm
- Internal diameter 0.5mm larger than incision
- Designed as a guide with the Ø8mm incision DK Epithelial Trephine 6-924
- Round handle, length 125mm

See above table for various incision diameters.

6-944-1

Bates Trephine Guide and Alcohol Chamber with Fixation (Ø8.0mm incision)

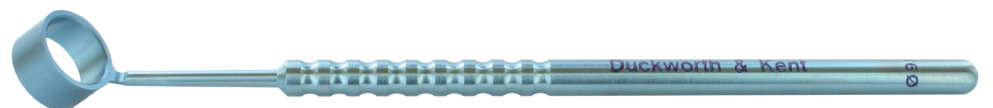
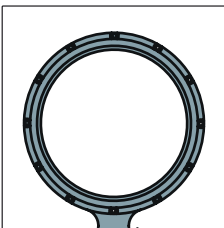
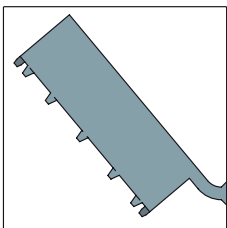

- Low profile alcohol chamber, height 4mm
- Internal diameter 0.5mm larger than incision
- Designed as a guide with the Ø8mm incision DK Epithelial Trephine 6-924
- Round handle, length 125mm

See above table for various incision diameters.

Markers

9-850

Pallikaris LASIK Blade Marker

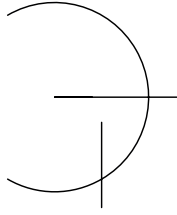
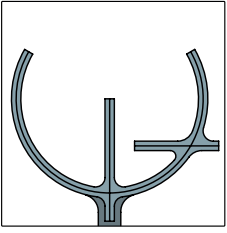

- Flat handle, length 106mm

Marks 10mm x 240° with central line from centre to 1.5mm beyond the diameter and line 90° to that line, 2.5mm below.

9-853

Bennett Thornton LASIK Marker

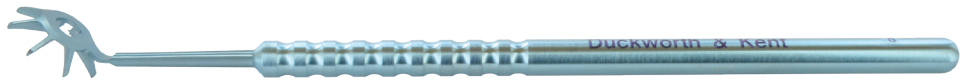
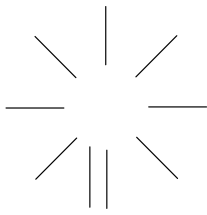
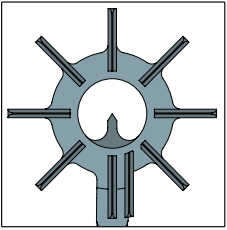

- Lowest profile with eight radial elements and non-radial element
- Round handle, length 128mm

Useful in realigning flap after repositioning following LASIK. Misalignment in any portion of flap can be readily seen since elements are at right angles to flap edges. The additional non radial element is useful in the event of a free flap. This position permits surgeon to properly orient flap and prevent flap from being laid upside down. Overall length of elements ensures flap edges will be included in the mark regardless of flap size. Open centre with pointer ensures simple and accurate marking on cornea, 45° angulation of head allows for ease and comfort in use.

9-854R

LASIK Marker

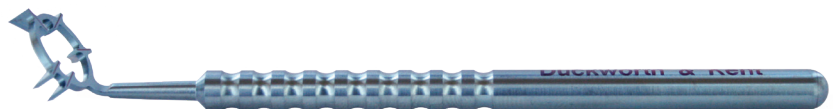
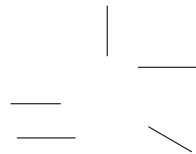
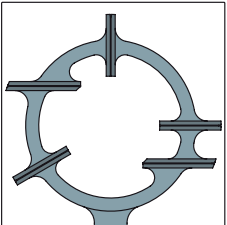

- Lowest profile with three radial elements and two non-radial elements
- Round handle, length 98mm

9-855

Gulani LASIK Marker

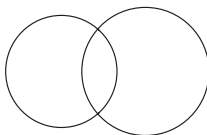
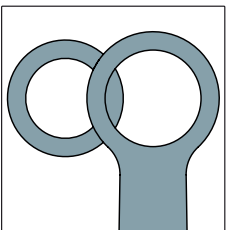

- 3.5mm and 4mm intersecting circles
- Round handle, length 122mm

Double circle marker (3.5mm and 4mm) provides pre-determined landmark (four reference points of two intersecting circles) for corneal flap replacement following excimer laser ablation of stromal bed in LASIK. Configuration of arcs of intersecting circles allows correct side-up placement of corneal flap.

Dissectors and Knives

6-607

Morlet Lamellar Knife / Dissector

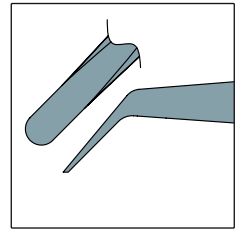
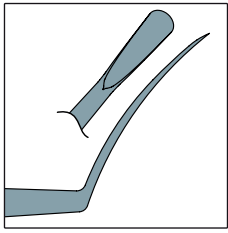

Dissector

- 0.35mm x 2mm curved
- Angled shafts 12mm tip to curve

Knife

- 0.1mm x 1.5mm with sharp edges
- Tip to angle length 3mm
- Round handle, length 111mm

Combined Paufigue knife and lamellar corneal dissector. Paufigue knife used for starting lamellar corneal dissection and also to extend while peeling back superficial corneal tissue. Also used for undermining the periphery of host lamellar corneal bed which helps to prevent development of a step at the anterior host donor junction when implanting a donor lamellar that is thicker than excised host lamellar. Paufigue knife also used to for removing lamellar host tissue down to level of Descemet's membrane. Lamellar corneal dissector is used to create a lamellar corneal plane via a peripheral corneal pocket or to widely extend a lamellar dissection that has been started with Paufigue knife. Designed to separate lamellae and to stay within a plane. Corneal lamellae can be rapidly separated with this instrument without the need for lifting and turning back lamellar flap. After separating the layers, lamellar corneal button may be excised with scissors.

6-609

Barrett Lamellar Dissector / Knife

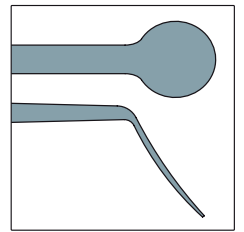
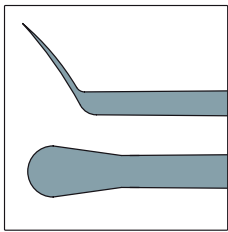

Knife

- 2mm sharp rounded tip
- 55° angled shaft, tip to angle length 6mm
- Barrett balanced set handle, length 121mm

Dissector

- 4mm round blunt edge
- 55° angled shaft, tip to angle length 6mm

Key Benefits of Titanium

- Titanium's lightness is a positive aid to assisting instrument handling by the surgeon.
- Instruments are anodised to provide a non-reflecting surface, essential in microsurgical operations.
- Titanium instruments withstand repeat sterilisation without compromise to edge or surface quality, strength and are corrosion resistant.
- Titanium is non-magnetic and therefore does not cause adverse reactions with other steel instruments or equipment.

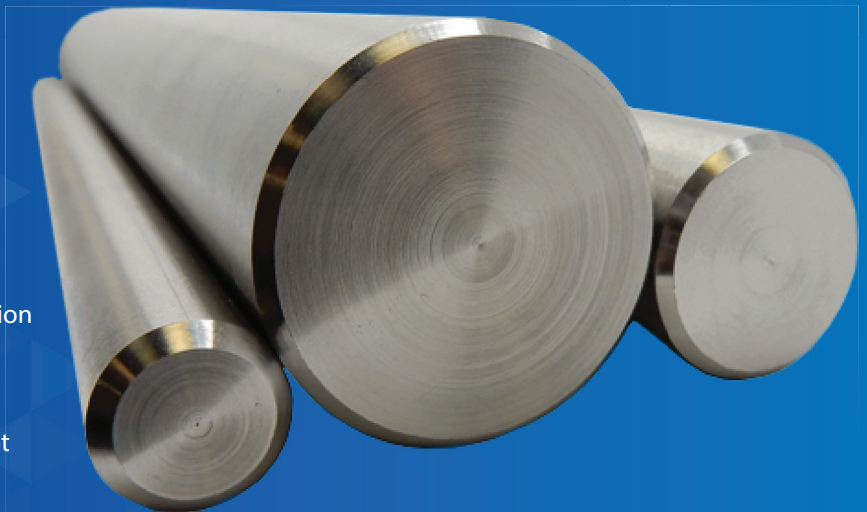

Spatulas and Flap Lifters

6-870

Buratto LASIK Oval Spatula

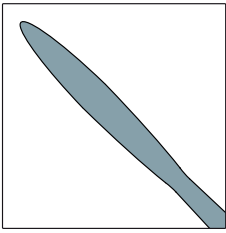

- 1.3mm curved blade
- 35° angled curved shaft
- Tip to angle length 10.5mm
- Round handle, length 122mm

Designed to raise flap during LASIK.

6-870-1

Buratto LASIK Oval Spatula

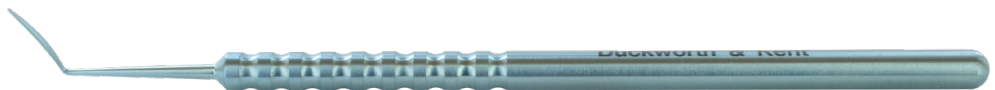
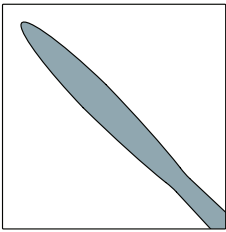

- 1.3mm curved blade
- 60° angled curved shaft
- Tip to angle length 10.5mm
- Round handle, length 119mm

Designed to raise flap during LASIK.

6-858

Stevens Femto Flap Lifter

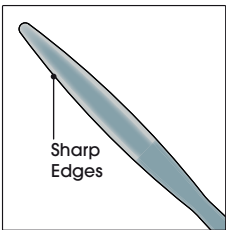

- Thin curved blade
- 1.3mm wide with sharp edges
- 35° angled curved shaft
- Tip to angle length 10.5mm
- Round handle, length 122mm

The curved design of the Stevens Femto Flap Lifter glides smoothly to raise the flap, whilst the sharp edges are used to separate the adhesions under the flap that are left after the femtosecond laser.

6-859

Stevens Femto Flap Lifter, narrow tip

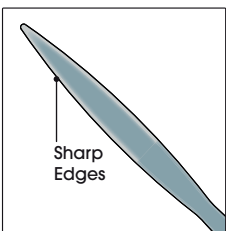

- Thin curved blade with narrow pointed tip
- 1.3mm wide, sharp edges
- 35° angled curved shaft
- Tip to angle length 10.5mm
- Round handle, length 122mm

The curved design of the Stevens Femto Flap Lifter glides smoothly to raise the flap, whilst the sharp edges are used to separate the adhesions under the flap that are left after the femtosecond laser.

Spatulas and Flap Lifters

6-848

Krokchings Femto Incision Opening Spatula

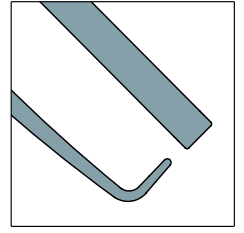
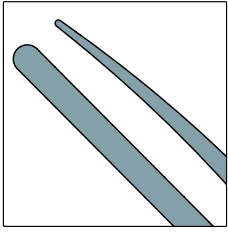

Femto Spatula

- Fine flat tip, 0.5mm width
- 4mm slightly curved spatula blade
- Opens primary and secondary femto created incisions

Femto Spatula

- 4mm slightly curved spatula blade
- Fine point, 0.5mm wide x 0.5mm 90° angled tip
- Opens limbal relaxing incisions (LRI)
- Round handle, length 119mm

6-850

Cionni Femto Spatula and Nucleus Divider

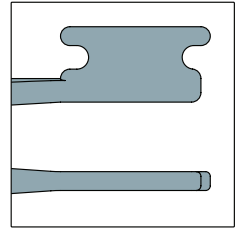
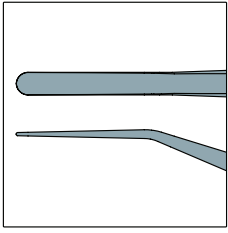

Femto Spatula

- Fine point, 0.5mm width
- 3mm spatula blade
- Opens primary and secondary femto created incisions

Nucleus Divider

- Blade 1.6mm x 0.8mm
- Used for pushing and pulling the iris or anterior capsule edge
- Round handle, length 131mm

6-855

DK Femto Flap Lifter and Retreatment Spatula

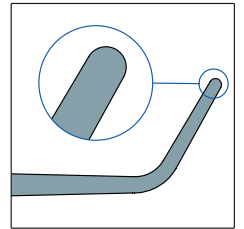
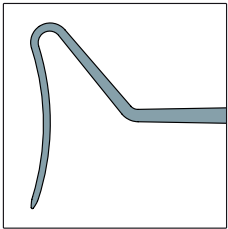

Flap lifter

- 0.4mm diameter, smooth polished surface
- Curved shaft, 12mm length

Retreatment Spatula

- 0.15mm tip diameter, smooth polished surface
- Tip to angle length 3mm
- Round handle, length 123mm

6-855-1

DK Femto Flap Lifter and Retreatment Spatula - Bullet Shaped Tip

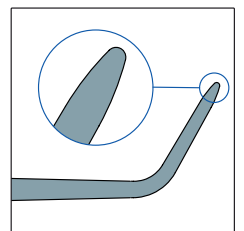
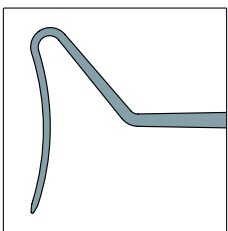

Flap lifter

- 0.4mm diameter, smooth polished surface
- Curved shaft, 12mm length

Retreatment Spatula

- 0.15mm tip diameter, smooth polished surface
- Bullet shaped tip
- Tip to angle length 3mm
- Round handle, length 123mm

Spatulas and Flap Lifters

6-857

Stevens Femto Rim Lifter

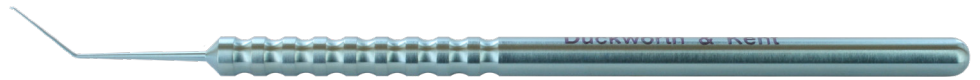
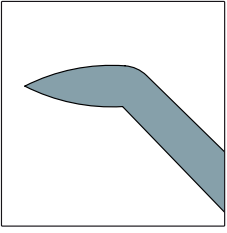

- Sharp bullet shaped tip, 0.5mm long
- 45° angled shaft, tip to angle length 10mm
- Round handle, length 119mm

The sharp tip of the Stevens Femto Rim Lifter is used after the femtosecond laser to sweep along the rim to delineate and open the flap.

6-103-1

DK Double Ended Spatula (for repositioning epithelial flap)

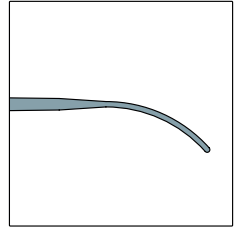
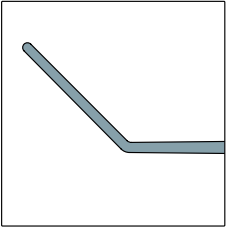

- 0.8mm diameter, double ended, one curved and one straight
- 45° angled shaft, tip to angle length 12mm
- Round handle, length 127mm

6-866

DK Epithelial Separator / Lifter

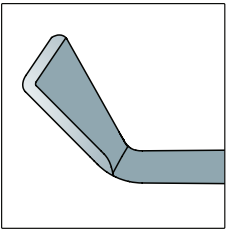

- 5mm triangular-shaped tip
- 45° angled shaft
- Round handle, length 115mm

6-856

Femto Laser Spatula

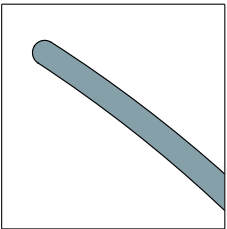

- 0.5mm spatula
- Smooth slightly curved shaft with blunt tip
- 45° angled shaft, tip to angle length 10mm
- Round handle, length 118mm

Choppers

6-071

Scott Femto Chop

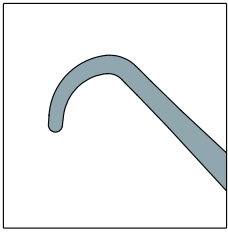

- Curved, smooth round tip
- Tip to angle length 10mm
- 45° angled shaft

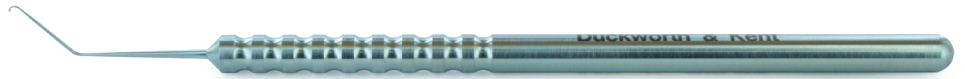

- Round handle, length 120mm
- 0.45 constant diameter shaft to reduce leakage

Designed for the lens that has been femtosecond laser treated and is being removed with zero or little ultrasound power. Scott Femto Chop Technique and Scott Endolenticular Viscodissection involve segmenting the lens along the femto segment treatment lines and then using the curve of the tip to manipulate the segments into the central anterior chamber. The curve also avoids inadvertent damage to the capsule. While removing the segments, the curve of the chop is placed in close proximity to the phaco tip and protects the tip from contact with the capsule. The shaft of the chop is a consistent diameter and helps control fluid egress, helping to stabilise the anterior chamber.

Forceps

2-795E

Stein Utility / Flap Lifting Forceps

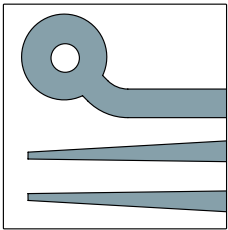

- Small flat ring tips
- 45° angled shafts, tip to angle length 4mm
- Flat handle, length 90mm
- Design registration number 004383396-0001



Designed with shortened, small flat ring tips for removal of contact lens at slit lamp biomicroscope. Useful contact lens removal following PRK and other refractive surgical procedures.

Cannulas

8-604

23g

DK LASIK Cannula

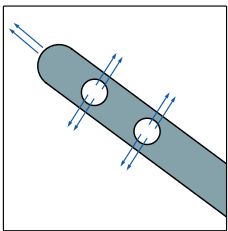

- 23 gauge tube (0.65mm diameter)
- 0.2mm diameter hole at tip
- Four 0.4mm diameter holes along side of shaft

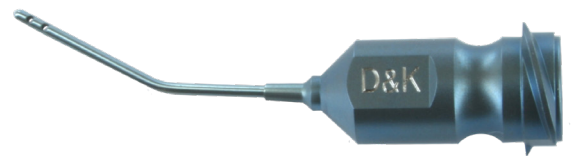

- 25° angled shaft, tip to angle length 8mm
- Overall length 30mm

Visit: www.duckworth-and-kent.com to view
a wide range of ophthalmic titanium instruments

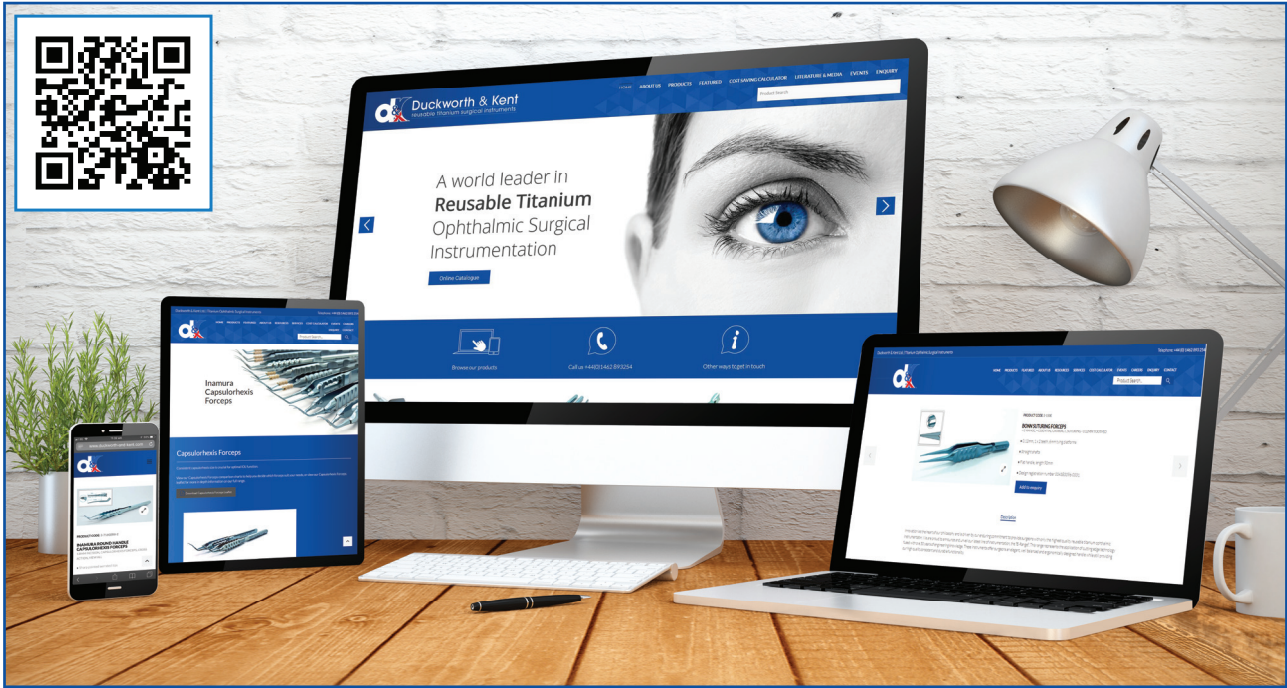

As well as product information for a wide range of instruments, you will also find detailed literature and informative videos showing some of our instruments in action.

Duckworth & Kent Promotional Ranges

See the Quality Feel the Difference

CORE VALUES
Collection

E-RANGE
Instruments

Essential
CATARACT SET

Connect



Maria
Customer
Service
Supervisor



Kelly
Customer
Service



Nicky
Customer
Service



If you are interested in our product ranges or have a general enquiry, please contact our dedicated customer service team.

mariagentle@
kellyobrien@
nickyguthrie@ } duckworth-and-kent.co.uk

Find us on



© February 2012 Duckworth & Kent
Revised 26.04.19
Email: info@duckworth-and-kent.co.uk
Tel: +44 (0)1462 893254
Fax: +44 (0)1462 896288

www.duckworth-and-kent.com

D&K® is a registered trademark. All other brand names are trademarks or registered trademarks of their respective owners. All schematic line drawings, photographs and copy in this leaflet are fully protected by copyright. No part of this leaflet may be reproduced in any form without prior written permission. We reserve the right to make changes at any time, without notice, in product specifications and availability. Descriptive, typographic, or photographic errors are subject to correction. Name(s) of instruments are often comprised of surgeon's name, combination of surgeons' names or by the category of the instrument.